

GDE25S12B Series DC-DC Converters Technical Manual V1.0

**Eighth-Brick
DC-DC Converters**

36 - 75 V Input

12 V/25 A Output

Negative logic

Description

The GDE25S12B series are new isolated DC-DC converters that use an industry standard eighth-brick structure and feature high efficiency and power density with low output ripple and noise. They operate from an input voltage range of 36 V to 75 V, and provide the rated output voltage of 12 V as well as the maximum output current of 25 A.

Operational Features

- Input voltage: 36 - 75 V
- Output current: 0 - 25 A
- Efficiency: 95% (12 V, 25A)

Mechanical Features

- Industry standard eighth-brick (L x W x H):
58.4 mm x 22.9 mm x 13.2 mm (2.30 in. x
0.90 in. x 0.52 in.)
- Weight: 45 g

Control Features

- Remote On/Off
- PMBus communication

Protection Features

- Input undervoltage protection
- Output overcurrent protection (Hiccup mode)
- Output short circuit protection (Hiccup mode)
- Output overvoltage protection (Hiccup mode)
- Overtemperature protection (Self-recovery)

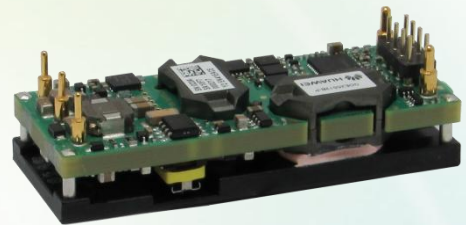
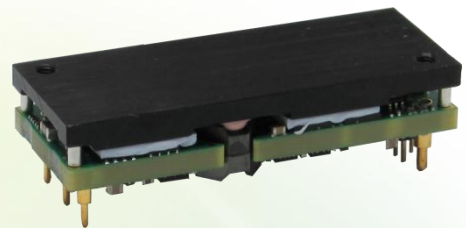

Safety Features

- CE, UL certification
- UL60950-1, C22.2 No. 60950-1 and EN 60950-1
- RoHS6 compliant

Applications

- Servers
- Telecom and Data Communication Applications
- Industrial Equipment

GDE25S12B Series

DC-DC Converters Technical Manual V1.0

Product Codes

Product Codes	Internal Model	Remote ON/OFF	Pin Length	PMBus	PMBus Pin Length
GDE25S12B-P	EN41EACE	Negative	3.8 mm	Yes	3.8 mm
GDE25S12B	EN41EACF	Negative	3.8 mm	No	No

NOTE

In this document, the description about PMBus and the parallel connection and output voltage adjustment functions apply only to modules with PMBus pins. These functions are unavailable to modules without PMBus pins.

Designation Explanation

GDE 25 S 12 B -P
1 2 3 4 5 6

1	Model series	GDE: 48 V input, high performance, digital control eighth-brick
2	Output current	25: 25 A output current
3	Output number	S: single output
4	Output voltage	12: 12 V output
5	Baseplate	B: with a baseplate
6	PMBus	P: with PMBus Default: without PMBus function

GDE25S12B Series DC-DC Converters Technical Manual V1.0

Mechanical Diagram

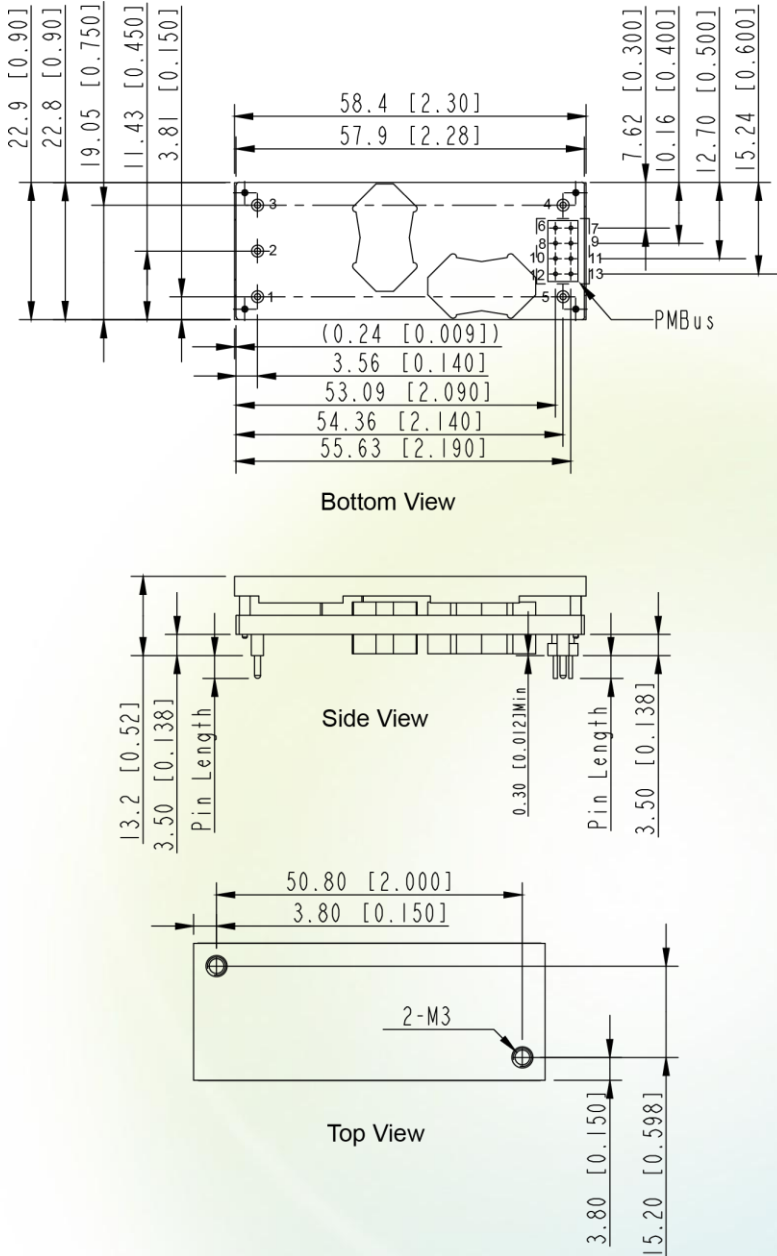

Pin Description

No.	GDE25S12B-P	GDE25S12B
1	V _{in} (+)	V _{in} (+)
2	On/Off	On/Off
3	V _{in} (-)	V _{in} (-)
4	V _{out} (-)	V _{out} (-)
5	V _{out} (+)	V _{out} (+)
6	GND	NC
7	SA0	NC
8	SYNC	NC
9	NC	NC
10	PMBus_CTL	NC
11	ISHARE	NC
12	PMBus_SCL	NC
13	PMBus_SDA	NC



NOTE

- All dimensions in mm [in.]
Tolerances: x.x ± 0.5 mm [x.xx ± 0.02 in.] x.xx ± 0.25 mm [x.xxx ± 0.010 in.]
- Pin 1-3 are 1.00 ± 0.05 mm [0.040 ± 0.002 in.] diameter with 2.00 ± 0.10 mm [0.080 ± 0.004 in.] diameter standoff shoulders. Pin 4 and pin 5 are 1.5 ± 0.05 mm [0.060 ± 0.002 in.] diameter with 2.50 ± 0.10 mm [0.098 ± 0.004 in.] diameter standoff shoulders. Pin 6-13 are 0.64 ± 0.05 mm [0.025 ± 0.002 in.]
- M3 Screw used to bolt unit's baseplate to other surfaces (such as heatsink) must not exceed 3.2 mm [0.126 in.] depth below the surface of baseplate.

GDE25S12B Series

DC-DC Converters Technical Manual V1.0

Electrical Specifications

Conditions: $T_A = 25^\circ\text{C}$ (77°F), Airflow = 1 m/s (200 LFM), $V_{in} = 48\text{ V}$, unless otherwise notes.

Parameter	Min.	Typ.	Max.	Unit	Notes & Conditions
Absolute maximum ratings					
Input voltage					
Continuous	-	-	80	V	-
Transient (100 ms)	-	-	100	V	-
Operating ambient temperature	-40	-	85	$^\circ\text{C}$	See the thermal derating curve
Storage temperature	-55	-	125	$^\circ\text{C}$	-
Operating humidity	10	-	95	% RH	Non-condensing
External voltage applied to On/Off	-	-	12	V	-
External voltage applied to PMBus port	-	-	3.6	V	-
Input characteristics					
Operating input voltage	36	48	75	V	-
Maximum input current	-	-	9.5	A	$V_{in} = 0 - 75\text{ V}$; $I_{out} = 25\text{ A}$
No-load loss	-	6	9	W	$V_{in} = 48\text{ V}$; $I_{out} = 0\text{ A}$
Input capacitance	100	330	-	μF	Aluminum electrolytic capacitor
Inrush transient	-	-	2	A^2s	-
Input reflected ripple current (peak to peak)	-	-	100	mA	Oscilloscope bandwidth: 20 MHz
Response to input Transient	-	1.5	2	V	Input transient: 0.5 V/ μs $V_{in} = 42 - 75\text{ V}$, 100% load
	-	-	3	V	Input transient: 0.5 V/ μs $V_{in} = 36 - 75\text{ V}$, 100% load
Output characteristics					
Output voltage set point	11.88	12.00	12.12	V	$V_{in} = 48\text{ V}$; $I_{out} = 12.5\text{ A}$
Output voltage range	11.64	-	12.36	V	$V_{in} = 42 - 75\text{ V}$; $I_{out} = 25\text{ A}$
	10	-	12.36	V	$V_{in} = 36 - 42\text{ V}$; $I_{out} = 25\text{ A}$
Output current	0	-	25	A	-
Output power	0	-	300	W	-
Output line regulation	-0.3	-	0.3	% V_{out}	$V_{in} = 42 - 75\text{ V}$; $I_{out} = 25\text{ A}$
	-17	-	17	% V_{out}	$V_{in} = 36 - 42\text{ V}$; $I_{out} = 25\text{ A}$
Output load regulation	-4	-	4	% V_{out}	$V_{in} = 48\text{ V}$; $I_{out} = I_{omin} - I_{onom}$
Temperature coefficient	-0.02	-	0.02	%/ $^\circ\text{C}$	$T_A = -40^\circ\text{C}$ to $+85^\circ\text{C}$ (-40°F to $+185^\circ\text{F}$)

GDE25S12B Series

DC-DC Converters Technical Manual V1.0

Electrical Specifications

Conditions: $T_A = 25^\circ\text{C}$ (77°F), Airflow = 1 m/s (200 LFM), $V_{in} = 48\text{ V}$, unless otherwise notes.

Parameter	Min.	Typ.	Max.	Unit	Notes & Conditions
Output characteristics					
External capacitance	440	680	10^4	μF	SMD aluminum solid capacitor or chip aluminum capacitor. When the temperature is lower than -5°C , the type of the external capacitance should be SMD aluminum solid capacitor, and the value at least $1000\ \mu\text{F}$
Regulated voltage precision	-5	-	5	%	$V_{in} = 42 - 75\text{ V}$; $I_{out} = I_{omin} - I_{onom}$
	-18	-	18	%	$V_{in} = 36 - 42\text{ V}$; $I_{out} = I_{omin} - I_{onom}$
Output ripple and noise (peak to peak)	-	50	250	mV	Oscilloscope bandwidth: 20 MHz
Output voltage adjustment range	5	-	13.2	V	$V_{in} = 48 - 75\text{ V}$; Adjust the voltage by the PMBus
	5	-	$0.2V_{in} + 3.6$	V	$V_{in} = 36 - 48\text{ V}$; Adjust the voltage by the PMBus
Output voltage overshoot	-	-	5	%	The whole range of V_{in} , I_{out} and T_A
Output voltage delay time	-	50	100	ms	From V_{in} connection to $10\%V_{out}$
Output voltage rise time	-	50	100	ms	From $10\%V_{out}$ to $90\%V_{out}$
Switching frequency	-	180	-	kHz	-
Protection characteristics					
Input undervoltage protection					
Startup threshold	32	34	36	V	-
Shutdown threshold	30	32	34	V	-
Hysteresis	1	2	3	V	-
Output overcurrent protection	110	-	140	$\%I_{omax}$	Hiccup mode
Output short circuit protection	-	-	-	-	Hiccup mode
Output overvoltage protection	120	-	140	$\%V_{oset}$	Hiccup mode
Overtemperature protection					
Threshold	105	115	130	$^\circ\text{C}$	Self-recovery
Hysteresis	5	-	-	$^\circ\text{C}$	
Efficiency					
100% load	94.0	95.0	-	%	$V_{in} = 48\text{ V}$; $V_{out} = 12\text{ V}$
	90.0	91.0	-	%	$V_{in} = 48\text{ V}$; $V_{out} = 5\text{ V}$
50% load	94.5	95.5	-	%	$V_{in} = 48\text{ V}$; $V_{out} = 12\text{ V}$
	91.0	92.0	-	%	$V_{in} = 48\text{ V}$; $V_{out} = 5\text{ V}$

GDE25S12B Series

DC-DC Converters Technical Manual V1.0

Electrical Specifications

Conditions: $T_A = 25^\circ\text{C}$ (77°F), Airflow = 1 m/s (200 LFM), $V_{in} = 48\text{ V}$, unless otherwise notes.

Parameter	Min.	Typ.	Max.	Unit	Notes & Conditions
Efficiency					
20% load	92.0	93.0	-	%	$V_{in} = 48\text{ V}$; $V_{out} = 12\text{ V}$
	87.5	88.5	-	%	$V_{in} = 48\text{ V}$; $V_{out} = 5\text{ V}$
Dynamic characteristics					
Overshoot amplitude	-	-	600	mV	Current change rate: 0.1 A/ μs $V_{in} = 42 - 75\text{ V}$;
Recovery time	-	-	200	μs	Load: 25% - 50% - 25%; 50% - 75% - 50%
Overshoot amplitude	-	-	600	mV	Current change rate: 1 A/ μs $V_{in} = 42 - 75\text{ V}$;
Recovery time	-	-	300	μs	Load: 25% - 50% - 25%; 50% - 75% - 50% (With 1000 μF load capacitor at output terminal)
Parallel characteristics					
Maximum parallel output power	0	-	480	W	$V_{in} = 42 - 75\text{ V}$
Unbalance of current equalization	-10	-	10	%	$V_{in} = 42 - 75\text{ V}$, $P_{out} \geq 200\text{ W}$
	-15	-	15	%	$V_{in} = 36 - 42\text{ V}$, $P_{out} \geq 200\text{ W}$
Input capacitance	2x100	-	-	μF	Aluminum electrolytic capacitor
Output external capacitance	2x440	-	10^4	μF	SMD aluminum solid capacitor or chip aluminum capacitor; When the temperature is lower than -5°C , the type of the external capacitance should be SMD aluminum solid capacitor, and the value at least 2000 μF
Maximum parallel start load	-	-	25	A	$V_{in} = 36 - 75\text{ V}$
Maximum output power delay time	2	-	-	s	$V_{in} = 36 - 75\text{ V}$
Current equalization adjustment	-	-	0.8	V	$V_{in} = 36 - 75\text{ V}$; $P_{out} = 0 - 480\text{ W}$ (Adjust output voltage up & down by PMBus)
Output ripple and noise	-	50	250	mV	$V_{in} = 36 - 75\text{ V}$; $P_{out} = 0 - 480\text{ W}$; Oscilloscope bandwidth: 20 MHz
PMBus signal interface characteristics					
Logic input low (V_{IL})	-	-	0.8	V	-
Logic input high (V_{IH})	2.8	-	3.6	V	-
Logic output low (V_{OL})	-	-	0.25	V	$I_{OL} = 6\text{ mA}$
Logic output high (V_{OH})	0.6	-	3.6	V	$I_{OH} = -6\text{ mA}$

GDE25S12B Series

DC-DC Converters Technical Manual V1.0

Electrical Specifications

Conditions: $T_A = 25^\circ\text{C}$ (77°F), Airflow = 1 m/s (200 LFM), $V_{in} = 48\text{ V}$, unless otherwise notes.

Parameter	Min.	Typ.	Max.	Unit	Notes & Conditions
PMBus signal interface characteristics					
PMBus setting-up time	100	-	-	ns	For details about the values of T_{set} and T_{hold} , see Definition of I2C/PMBus Setting-up Time and Holding Time
PMBus holding time	0	-	-	ns	
PMBus detected precision					
Input voltage detected precision	-2	-	2	V	$V_{in} = 36 - 75\text{ V}$; $I_{out} = 0 - 25\text{ A}$; $T_A = -40^\circ\text{C}$ to $+85^\circ\text{C}$ (-40°F to $+185^\circ\text{F}$)
Output voltage detected precision	-0.2	-	0.2	V	
Output current detected precision	-2	-	2	A	
Temperature detected precision	-5	-	5	$^\circ\text{C}$	$V_{in} = 36 - 75\text{ V}$; $I_{out} = 0 - 25\text{ A}$; $T_A = -40^\circ\text{C}$ to $+125^\circ\text{C}$ (-40°F to $+257^\circ\text{F}$)
Other characteristics					
Remote On/Off voltage					
Low level	-0.7	-	1.2	V	Negative logic
High level	3.5	-	12	V	
On/Off current					
Low level	-	-	1.0	mA	-
High level	-	-	-	μA	-
PMBus_CTL voltage					
Low level	0	-	0.8	V	High level effective
High level	2.8	-	3.3	V	
PMBus_CTL current					
Low level	-	-	1	mA	-
Insulation characteristics					
Input to output Insulation voltage	-	-	1500	V DC	Functional Insulation; Leakage current < 1 mA
Input to baseplate Insulation voltage	-	-	750		
Output to baseplate Insulation voltage	-	-	750		
Reliability characteristics					
Mean time between failures (MTBF)	-	2.5	-	Million hours	Telcordia SR332; 80% load; Airflow = 1.5 m/s (300 LFM); $T_A = 40^\circ\text{C}$ (104°F)

Specifications are subject to change without notice.

GDE25S12B Series DC-DC Converters Technical Manual V1.0

Characteristic Curves

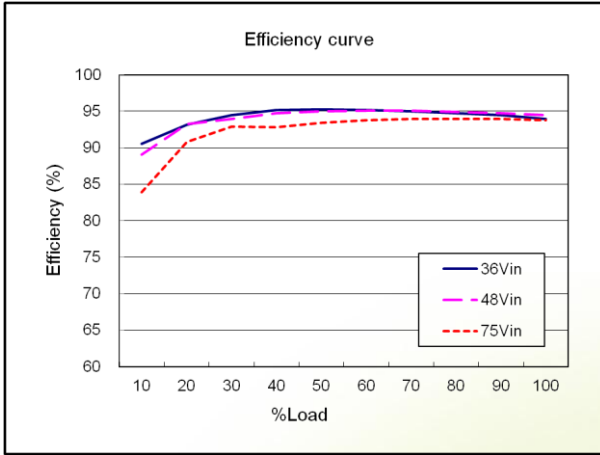

Figure 1: Efficiency ($T_A = 25^\circ\text{C}$ [77°F])

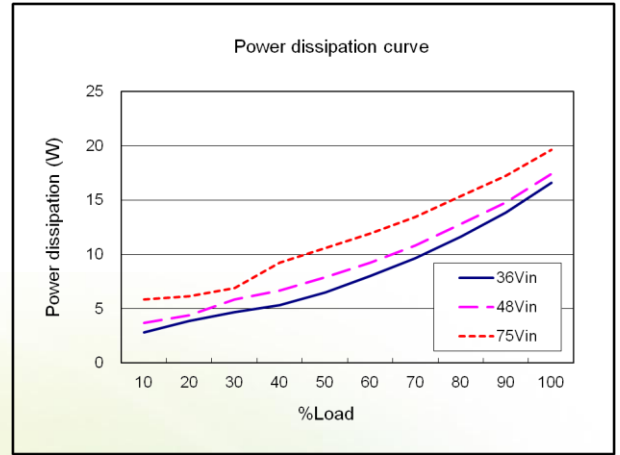

Figure 2: Power dissipation ($T_A = 25^\circ\text{C}$ [77°F])

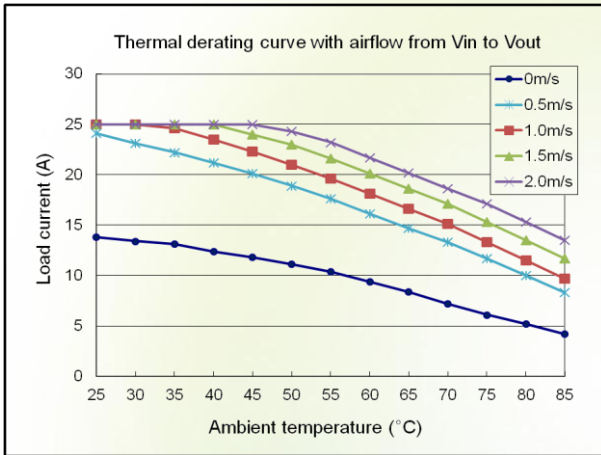

Figure 3: Thermal derating with airflow from V_{in} to V_{out} ($V_{in} = 48\text{ V}$; $V_{out} = 12\text{ V}$)

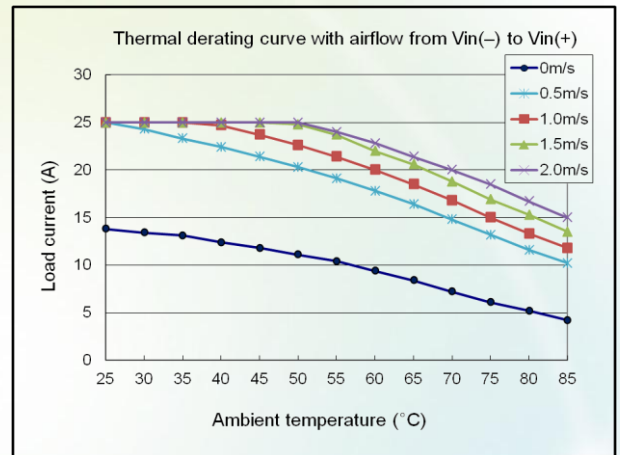

Figure 4: Thermal derating with airflow from $V_{in(-)}$ to $V_{in(+)}$ ($V_{in} = 48\text{ V}$; $V_{out} = 12\text{ V}$)

GDE25S12B Series DC-DC Converters Technical Manual V1.0

Typical Waveforms



NOTE

1. During the test of input reflected ripple current, the input terminal must be connected to the external input filter (include a 12 μH inductor and a 220 μF electrolytic capacitor), which is not required in other tests.
2. Points B and C, which are for testing the output voltage ripple, are 25 mm (0.98 in.) away from the $V_{\text{out}(+)}$ pin and the $V_{\text{out}(-)}$ pin.

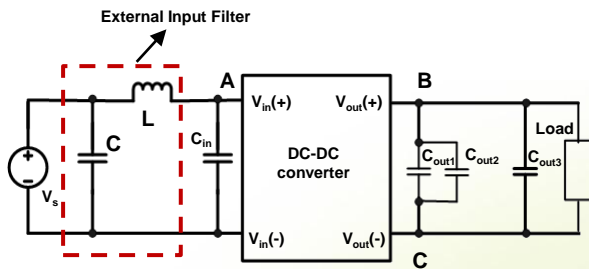

Figure 5: Test set-up diagram

C_{in} : The 100 μF aluminum electrolytic capacitor is recommended.

C_{out1} : The 0.1 μF ceramic capacitor is recommended.

C_{out2} : The 10 μF tantalum capacitor is recommended.

C_{out3} : The 440 μF SMD aluminum solid capacitor is recommended.

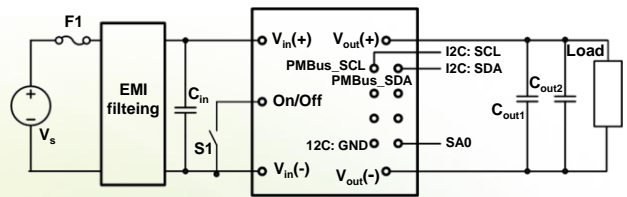

Figure 6: Typical circuit applications

F1: 20 A fuse (fast blowing)

C_{in} : The 100 μF aluminum electrolytic capacitor is recommended.

C_{out1} : The 1 μF ceramic capacitor is recommended.

C_{out2} : The 440 μF SMD aluminum solid capacitor is recommended.

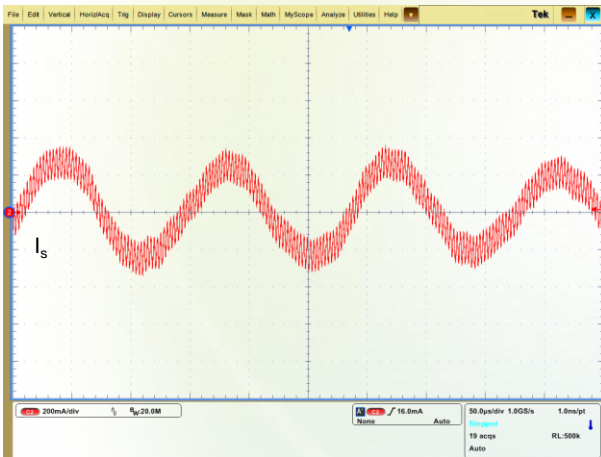

Figure 7: Input reflected ripple current
(For point A in the test set-up diagram, $V_{\text{in}} = 48 \text{ V}$, $V_{\text{out}} = 12 \text{ V}$, $I_{\text{out}} = 25 \text{ A}$)

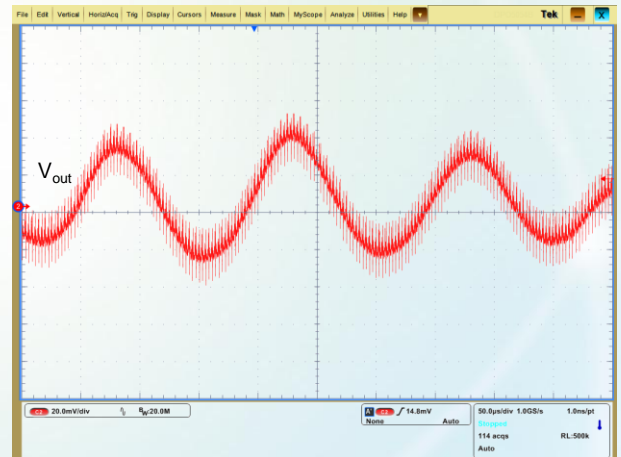

Figure 8: Output voltage ripple
(For point BC in the test set-up diagram, $V_{\text{in}} = 48 \text{ V}$, $V_{\text{out}} = 12 \text{ V}$, $I_{\text{out}} = 25 \text{ A}$)

GDE25S12B Series DC-DC Converters Technical Manual V1.0

Typical Waveforms

Conditions: $T_A = 25^\circ\text{C}$ (77°F), $V_{in} = 48\text{ V}$.

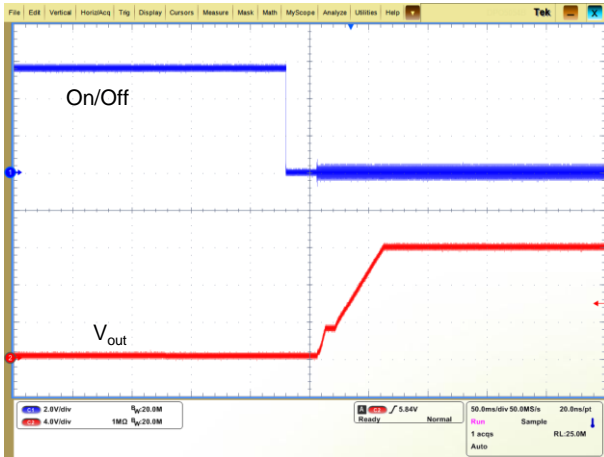

Figure 9: Startup from On/Off

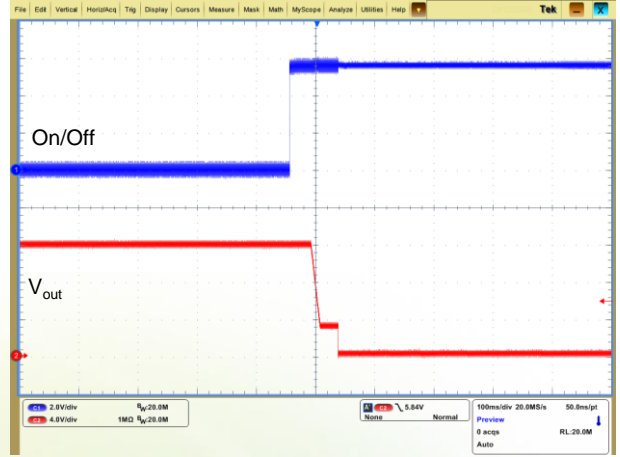

Figure 10: Shutdown from On/Off



Figure 11: Startup by power on

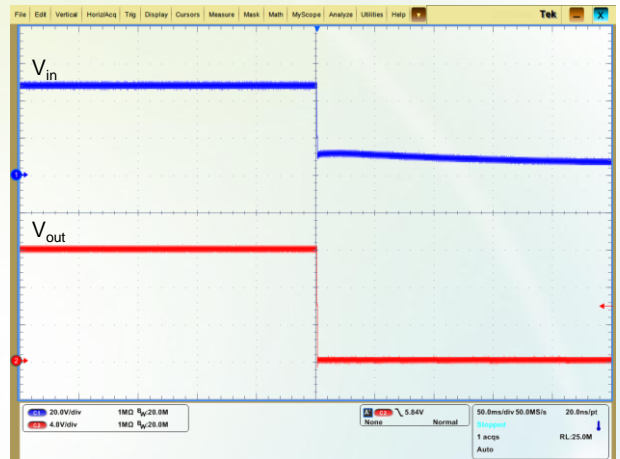

Figure 12: Shutdown by power off

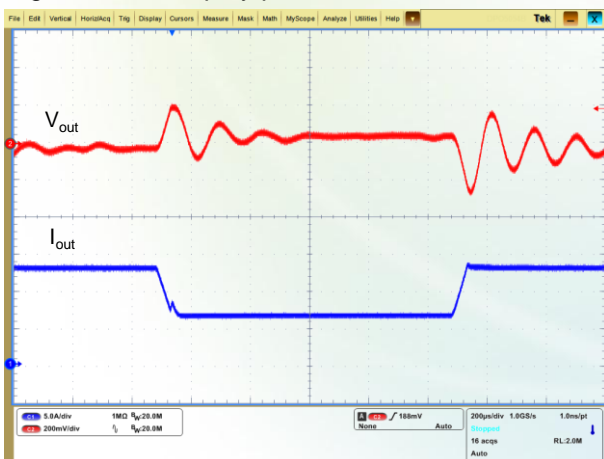

Figure 13: Output voltage dynamic response
(Load: 50% - 25% - 50%, $V_{in} = 42 - 75\text{ V}$, $di/dt = 0.1\text{ A}/\mu\text{s}$)

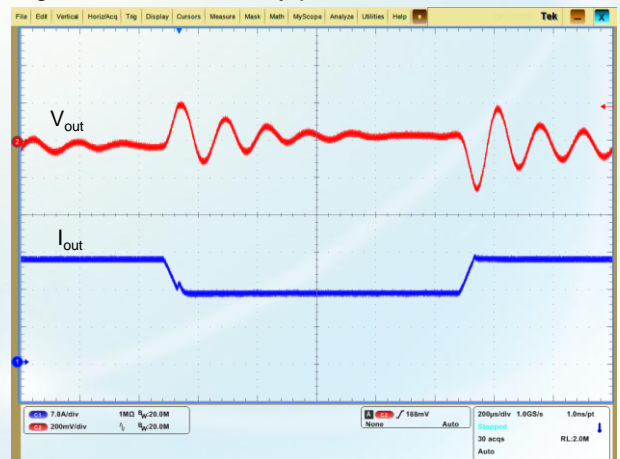

Figure 14: Output voltage dynamic response
(Load: 75% - 50% - 75%, $V_{in} = 42 - 75\text{ V}$, $di/dt = 0.1\text{ A}/\mu\text{s}$)

GDE25S12B Series DC-DC Converters Technical Manual V1.0

Remote On/Off

Logic Enable	On/Off Pin Level	Status
Negative logic	Low level	On
	High level or left open	Off

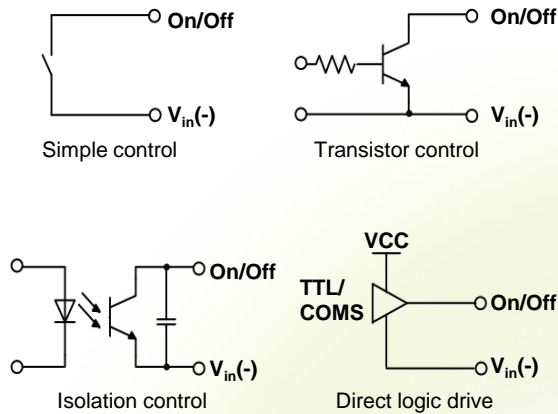

Figure 15: Various circuits for driving the On/Off pin

PMBus_CTL Enable Control

When the remote On/Off is in low level, the PMBus_CTL can perform secondary enable control.

PMBus_CTL Pin Level	Status
Low level	Disable
High level or left open	Enable

Output Startup Time

When the input voltage change rate is less than 0.3 V/ms, the output voltage rises to 10.2 V within 50 ms and then rises to terminal value at the rate of 0.065 V/s.

The maximum interval between 0 and t_1 is 50 ms, and maximum interval between t_1 and t_2 is 34s.

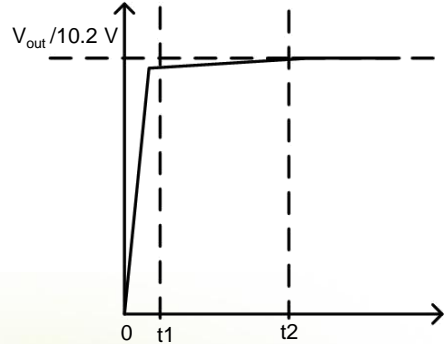

Figure 16: Output startup time

Parallel Operation

The products can be paralleled if external oring diodes or oring MOSFETs are used in series with the output.

Max parallel number is 2. Both of two SYNC pin should connect to each other together. Both of two ISHARE pin should connect to each other together.

NOTE

If two converters are connected in parallel, note the following:

1. Within 2 seconds after the converters start, the load current must not be less than or equal to 25 A.
2. The address of each converter is unique.

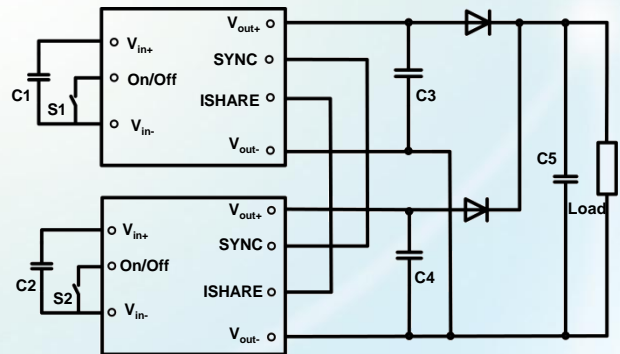

Figure 17: Parallel operation

NOTE

C1, C2: 100 μ F aluminum electrolytic capacitor.

C3, C4, C5: 440 μ F SMD aluminum solid capacitor and 1 μ F ceramic capacitor.

GDE25S12B Series DC-DC Converters Technical Manual V1.0

PMBus Address

The following table describes the mapping between the SA0 and PMBus address.
When the SA0 left open, PMBus address is 0X5B.
The relationship between PMBus address and SA0:

$$D = 12 \times 7 + SA0$$

D is the corresponding decimal number of PMBus address data. The decimal number is converted to a hexadecimal number when the data is written.

R _{SA0} (kΩ)	SA0 (V)	SA0 Address	PMBus Address
1-15	0-0.165	0	0X54
22	0.198-0.242	1	0X55
30	0.270-0.330	2	0X56
51	0.459-0.561	3	0X57
80.6	0.725-0.887	4	0X58
113	1.017-1.243	5	0X59
150	1.350-1.650	6	0X5A
>220 (left open)	1.980-2.500	7	0X5B

PMBus Communication

Monitor and Faults

The converter communicates with the system over the Power Management Bus (PMBus). The GDE25S12B Series provides the following monitoring and communication functions and fault detection functions.

Monitoring functions:

- Module information
- Input voltage
- Output voltage
- Output current
- Output power
- Module temperature
- On/Off frequency
- ISHARE sampling value

PMBus Communication

Faults detection functions:

- Reports faults for input undervoltage
- Reports faults for output overvoltage
- Reports faults for output overcurrent
- Reports faults for overtemperature

SCL and SDA

The SCL and SDA signal has an internal pull-up resistor, connected to the communication bus through the fault isolation circuit. Figure 18 shows the SCL and SDA external connections.

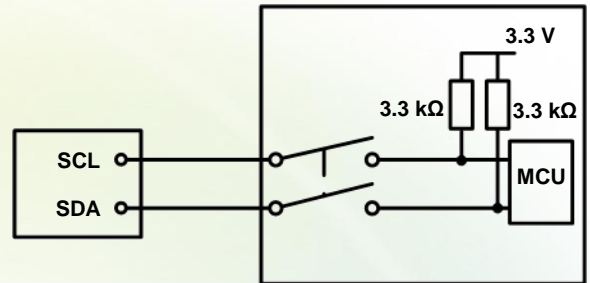

Figure 18: SCL and SDA external connections

Definition of I2C/PMBus Setting-up Time and Holding Time

The power supply supports both 100 kHz and 400 kHz clock rates, and 100 kHz is the default one. T_{set} is the duration for which SDA keeps its value unchanged before SCL increases. T_{hold} is the duration for which SDA keeps its value unchanged after SCL decreases. The communication will fail if the time is not consistent with the specifications.

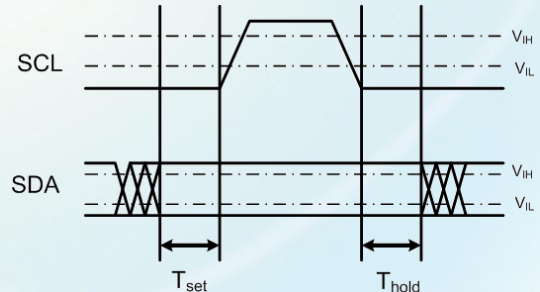

Figure 19: I2C/PMBus Setting-up Time and Holding Time

GDE25S12B Series DC-DC Converters Technical Manual V1.0

PMBus Communication

PMBus Commands

Hex Code	Command Name	Data Type	Data Bytes	Data Forma
Control commands				
01h	OPERATION	Read/Write Byte	1	-
03h	CLEAR_FAULTS	Send Byte	0	-
11h	STORE_DEFAULT_ALL	Send Byte	0	-
Output commands				
20h	VOUT_MODE	Read Byte	1	-
21h	VOUT_COMMAND	Read/Write Word	2	Linear 16
Alarm and fault commands				
40h	VOUT_OV_FAULT_LIMIT	Read Word	2	Linear 16
42h	VOUT_OV_WARNING_LIMIT	Read Word	2	Linear 16
46h	IOUT_OC_FAULT_LIMIT	Read Word	2	Linear 11
4Ah	IOUT_OC_WARNING_LIMIT	Read Word	2	Linear 11
4Fh	OT_FAULT_LIMIT	Read Word	2	Linear 11
51h	OT_WARNING_LIMIT	Read Word	2	Linear 11
58h	VIN_UV_WARNING_LIMIT	Read Word	2	Linear 11
59h	VIN_UV_FAULT_LIMIT	Read Word	2	Linear 11
Status commands				
78h	STATUS_BYTE	Read Byte	1	-
79h	STATUS_WORD	Read Word	2	-
7Ah	STATUS_VOUT	Read Byte	1	-
7Bh	STATUS_IOUT	Read Byte	1	-
7Ch	STATUS_INPUT	Read Byte	1	-
7Dh	STATUS_TEMPERATURE	Read Byte	1	-
7Eh	STATUS_CML	Read Byte	1	-
7Fh	STATUS_OTHER	Read Byte	1	-
80h	STATUS_MFR_SPECIFIC	Read Byte	1	-

Hex Code	Command Name	Data Type	Data Bytes	Data Format
Monitoring commands				
88h	READ_VIN	Read Word	2	Linear 11
8Bh	READ_VOUT	Read Word	2	Linear 16
8Ch	READ_IOUT	Read Word	2	Linear 11
8Eh	READ_TEMPERATURE	Read Word	2	Linear 11
95h	READ_FREQUENCY	Read Word	2	Linear 11
96h	READ_POUT	Read Word	2	Linear 11
D5h	READ_ISHARE	Read Word	2	Linear 11
Identification commands				
60h	TON_DELAY	Read/Write Word	2	Linear 11
61h	TON_RISE	Read Word	2	Linear 11
D1h	SOFT_VERSION	Read Word	2	-
F6h	PCB_VERSION	Read Word	2	-
98h	PMBUS_VERSION	Read Byte	1	-
99h	MFR_ID	Read Block	2	ASCII
9Ah	MFR_MODEL	Read Block	8	ASCII
9Bh	MFR_REVISION	Read Block	1	ASCII
9Ch	MFR_LOCATION	Read Block	4	ASCII
9Dh	MFR_DATE	Read Block	8	ASCII
D0h	PROTOCOL_TYPE	Read Word	2	-

Data Format

●Linear 11 Data Format

The linear data format is a two byte value with an 11-bit, binary signed mantissa (two's complement) and a 5-bit, binary signed exponent (two's complement), as shown in the following Figure 20.

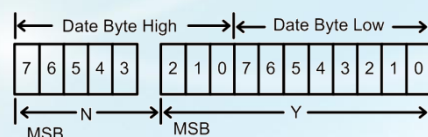

Figure 20: Linear 11 data format

GDE25S12B Series DC-DC Converters Technical Manual V1.0

PMBus Communication

The relationship between the N, Y, and Actual Value (V) is given by the following equation:

$$X = Y \times 2^N$$

where

X is the value

Y is the 11-bit, binary signed mantissa (two's complement).

N is the 5-bit, binary signed exponent (two's complement).

●VOUT Data Format

Commands related to output voltage are the VOUT_COMMAND, VOUT_OV_FAULT_LIMIT, VOUT_OV_WARNING_LIMIT and READ_VOUT. They are unsigned integers using the Linear 16 formats, as shown in the following Figure 21.

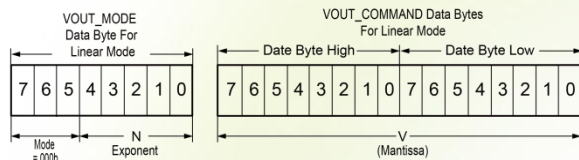

Figure 21: VOUT data format

The power supply is not required to support the VOUT_COMMAND, but must adhere to the VOUT data format. The output voltage is calculated as follows:

$$\text{Voltage} = V \times 2^N$$

where

Voltage is the output voltage value.

V is the 16-bit unsigned integer.

N is the 5-bit signed integer (two's complement).

Command Descriptions

OPERATION (01h): By default the Power supply is turned ON at power up as long as On/Off is active low. The Operation command is used to turn the Power Supply ON or OFF via the PMBus. The data byte below follows the OPERATION command.

Function	Data Byte
ON	0x80
OFF	0x00

CLEAR_FAULTS (03h): Clears all fault flags. Send this command to clear flags after a fault occurs.

STORE_DEFAULT_ALL (11h): Saves data after data calibration. If this command is not sent, the data will be lost after a power failure.

VOUT_MODE (20h): This command is used to determine the data type and parameters using PMBus command.

VOUT_COMMAND (21h): This command is used to change the output voltage of the power supply.

The default value is 12 V. Voltage margin range: 5 - 13.2 V.

TON_DELAY (60h): Indicates the delay time from startup command response to power output start. The preset value is 5 ms. The adjustment range is 5 - 1000 ms. The minimum adjustment scale is 1 ms.

The power supply is compliant with the Power PMBus Protocol Specification rev1.2 requirements. For details about the PMBus Commands, see the **PMBus Protocol Specification rev1.2**.

GDE25S12B Series DC-DC Converters Technical Manual V1.0

Input Undervoltage Protection

The converter will shut down after the input voltage drops below the undervoltage protection threshold for shutdown. The converter will start to work again after the input voltage reaches the input undervoltage protection threshold for startup. For the Hysteresis, see the **Protection characteristics**.

Output Overcurrent Protection

The converter equipped with current limiting circuitry can provide protection from an output overload or short circuit condition. If the output current exceeds the output overcurrent protection set point, the converter enters hiccup mode. When the fault condition is removed, the converter will automatically restart.

Output Overvoltage Protection

When the voltage directly across the output pins exceeds the output overvoltage protection threshold, the converter will enter hiccup mode. When the fault condition is removed, the converter will automatically restart.

Overtemperature Protection

A temperature sensor on the converter senses the average temperature of the module. It protects the converter from being damaged at high temperatures. When the temperature exceeds the overtemperature protection threshold, the output will shut down. It will allow the converter to turn on again when the temperature of the sensed location falls by the value of **Overtemperature Protection**.

Recommend Reverse Polarity Protection Circuit

Reverse polarity protection is recommended under installation and cabling conditions where reverse polarity across the input may occur.

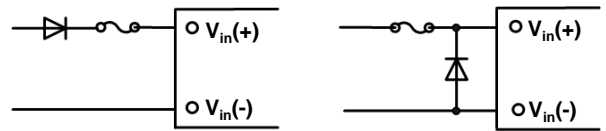

Figure 22: Recommend reverse polarity protection circuits

Recommended Fuse

The converter has no internal fuse. To meet safety and regulatory requirements, a 20 A fuse is recommended.

GDE25S12B Series DC-DC Converters Technical Manual V1.0

EMC

Figure 23 shows the EMC test set-up diagram. The acceptance standard is required as the conducted emission limits of CISPR22 Class A with 6 dB margin.

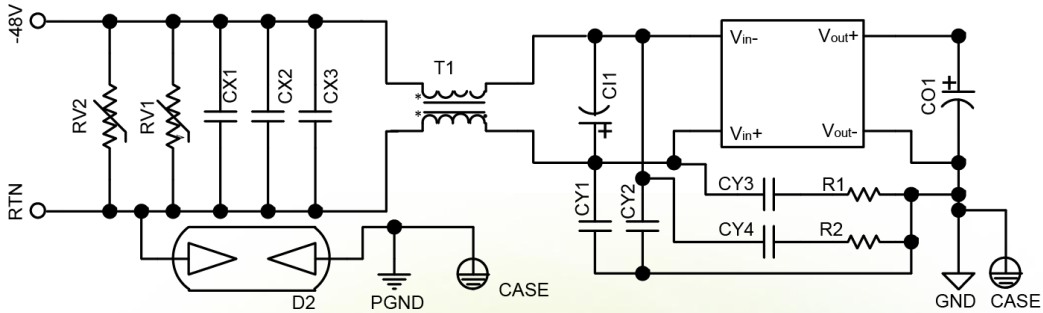

Figure 23: EMC test set-up diagram

RV1, RV2: Varistor, 100 V, 4500 A
D2: Gas discharge tube, 90 V, 10 kA

Cl1: Aluminum electrolytic capacitor, 100 V, 220+100 μ F
CO1: Non-solid DIP aluminum electrolytic capacitor, 100 V, 470 x 2 μ F

CX1, CX2, CX3: Metalized film capacitor, 275 V, 1 μ F
CY1, CY2: Metalized film capacitor, 275 V, 0.1 μ F
CY3, CY4: SMD ceramic capacitor, 1000 V, 22 nF

R1, R2: Chip thick film resistor, 1 W, 1 Ω
T1: Common mode inductor, single phase, 400 μ H

Qualification Testing

Parameter	Units	Condition
High Accelerated Life Test (HALT)	3	Low temperature limit: -60°C (-76°F); high temperature limit: 110°C (230°F); vibration limit: 40 G; temperature slope: 40°C (72°F) per minute
Temperature Humidity Bias (THB)	16	Maximum input voltage; 85°C (185°F); 85% RH; 1000 operating hours under lowest load power
High Temperature Operation Bias (HTOB)	16	Rated input voltage; air flow: 0.5 m/s (100 LFM) to 5 m/s (1000 LFM); ambient temperature between +45°C (+113°F) and +55°C (+131°F); 1000 operating hours; 50% to 80% load
Power and Temperature Cycling Test (PTC)	16	Rated input voltage; air flow: 0.5 m/s (100 LFM) to 5 m/s (1000 LFM); ambient temperature between -40°C (-40°F) and +85°C (+185°F); 1000 cycles; 50% load

GDE25S12B Series DC-DC Converters Technical Manual V1.0

Thermal Consideration

Thermal Test Point

Decide proper airflow to be provided by measuring the temperature of the PCB near the thermal resistor shown in Figure 24 to protect the converter against overtemperature. The overtemperature protection threshold is also obtained based on thermal test point.

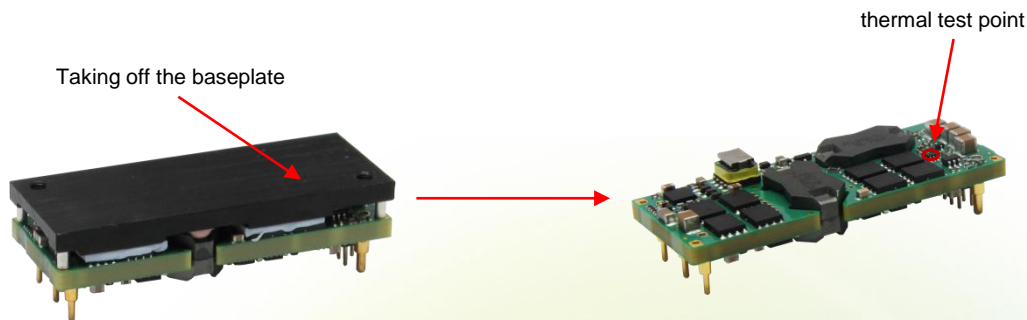

Figure 24: Thermal test point

Power Dissipation

The converter power dissipation is calculated based on efficiency. The following formula reflects the relationship between the consumed power (P_d), efficiency (η), and output power (P_o): $P_d = P_o(1 - \eta)/\eta$

Moisture Sensitivity Level (MSL) Rating

Store and transport the converter as required by the MSL rating 1 specified in the J-STD-020/033. The surface of a soldered converter must be clean and dry. Otherwise the assembly, test, or even reliability of the converters will be negatively affected.

Mechanical Consideration

Installation

Although the converter can be mounted in any direction, free airflow must be taken.

Soldering

The converter is compatible with standard wave soldering or hand soldering. No reflow soldering is allowed.

1. For wave soldering, the converter pins can be soldered at 260°C (500°F) for less than 7 seconds.
2. For hand soldering, the iron temperature should be maintained at 350°C (662°F) to 420°C (788°F) and applied to the converter pins for less than 10 seconds.

The converter can be rinsed using the isopropyl alcohol (IPA) solvent or other proper solvents.

HUAWEI TECHNOLOGIES CO., LTD.
Huawei Industrial Base Bantian Longgang
Shenzhen 518129
People's Republic of China
www.huawei.com